

- Pump** : **Manually operated bilge pump**
- Application** : **Removing bilge water from small undecked craft, dinghies or canoes..**
- Features** : No installation required
 Self priming
 Only non corrosive components
 Suitable for fresh, salt water and other fluids which may normally present in the bilge
- Construction** : Single action plunger pump
- Material, pump housing** : Polypropylene (PP)
- Connections for hose** : 28 mm (1 1/8")
- Hose, internal diam.** : 28 mm (1 1/8")
- length** : 1 m (40")
- Temperature** : Suitable for use in the range 0 to 60 degrees C. (32 to 140 degrees F.)

Specifications,

Type	BLPS05	BLPS08
Capacity:	0.5 litre/stroke (0.11 Imp Gallon/stroke) (0.13 US Gallon/stroke)	0.8 litre/stroke (0.18 Imp Gallon/stroke) (0.21 US Gallon/stroke)
	22.5 litres/45 strokes @ 10 kPa	36 litres/45 strokes @ 10 kPa
Maximum rise	not specified	
Weight	0.30 kg (0.66 lbs)	0.35 kg (0.77 lbs)

- Relevant CE Standards** : EN ISO 15083 (RCD - Bilge pump systems)
- Classification** : Non

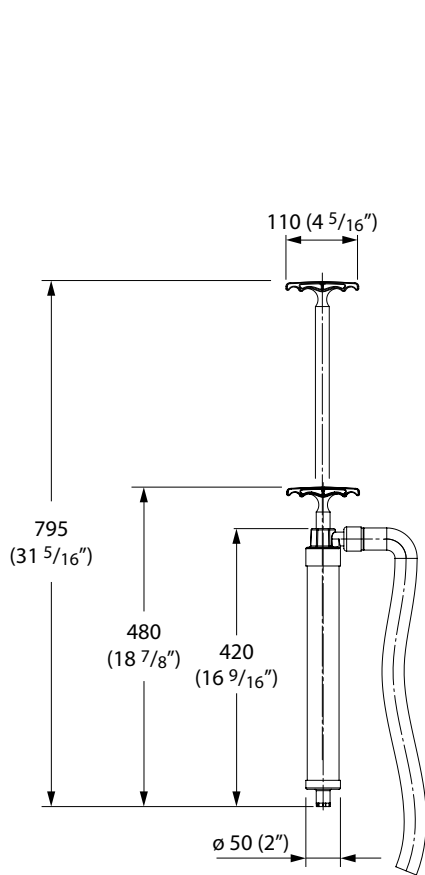

BLPS05

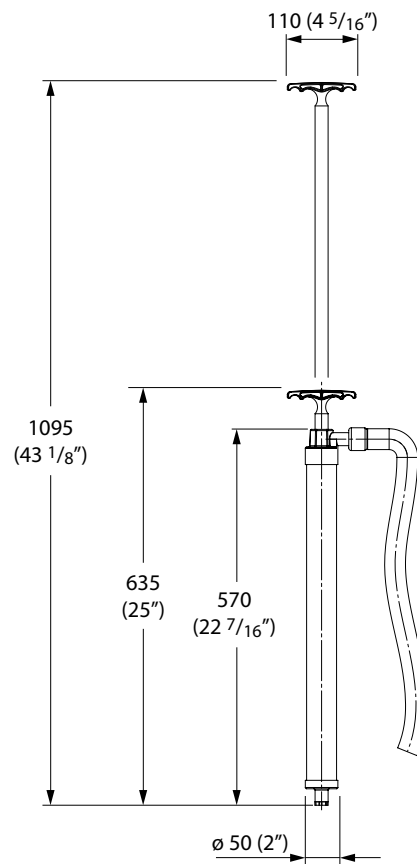

BLPS08

Overall dimensions